



Metroline

A MINIMALIST ALTERNATIVE TO TRADITIONAL TRACK.

A MINIMALIST ALTERNATIVE TO TRADITIONAL TRACK.

Metroline is a next-generation 48V **modular rail system** designed for **high performance, maximum flexibility, and a minimal aesthetic.**

It offers all the advantages of traditional track lighting while **reducing the rail profile** and expanding what the system can do. New modular capabilities introduce **more freedom** than conventional track systems ever allowed.

Where traditional track can feel visually heavy, Metroline's **slim rail** keeps ceilings clean and open, giving you design freedom without the bulk.

METROLINE RAIL

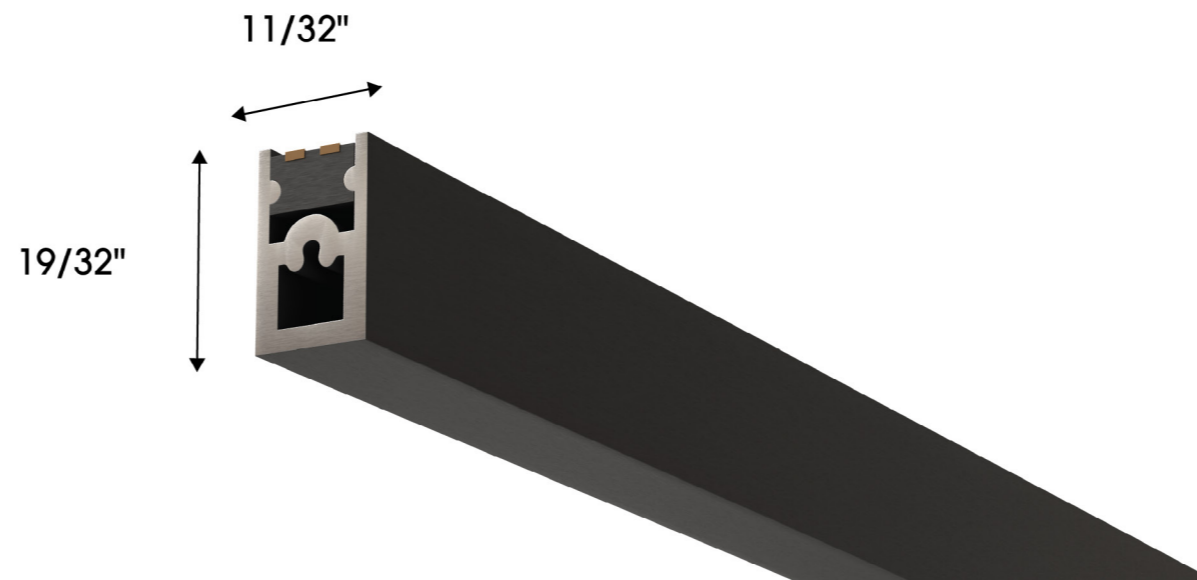

STANDARD CHANNEL

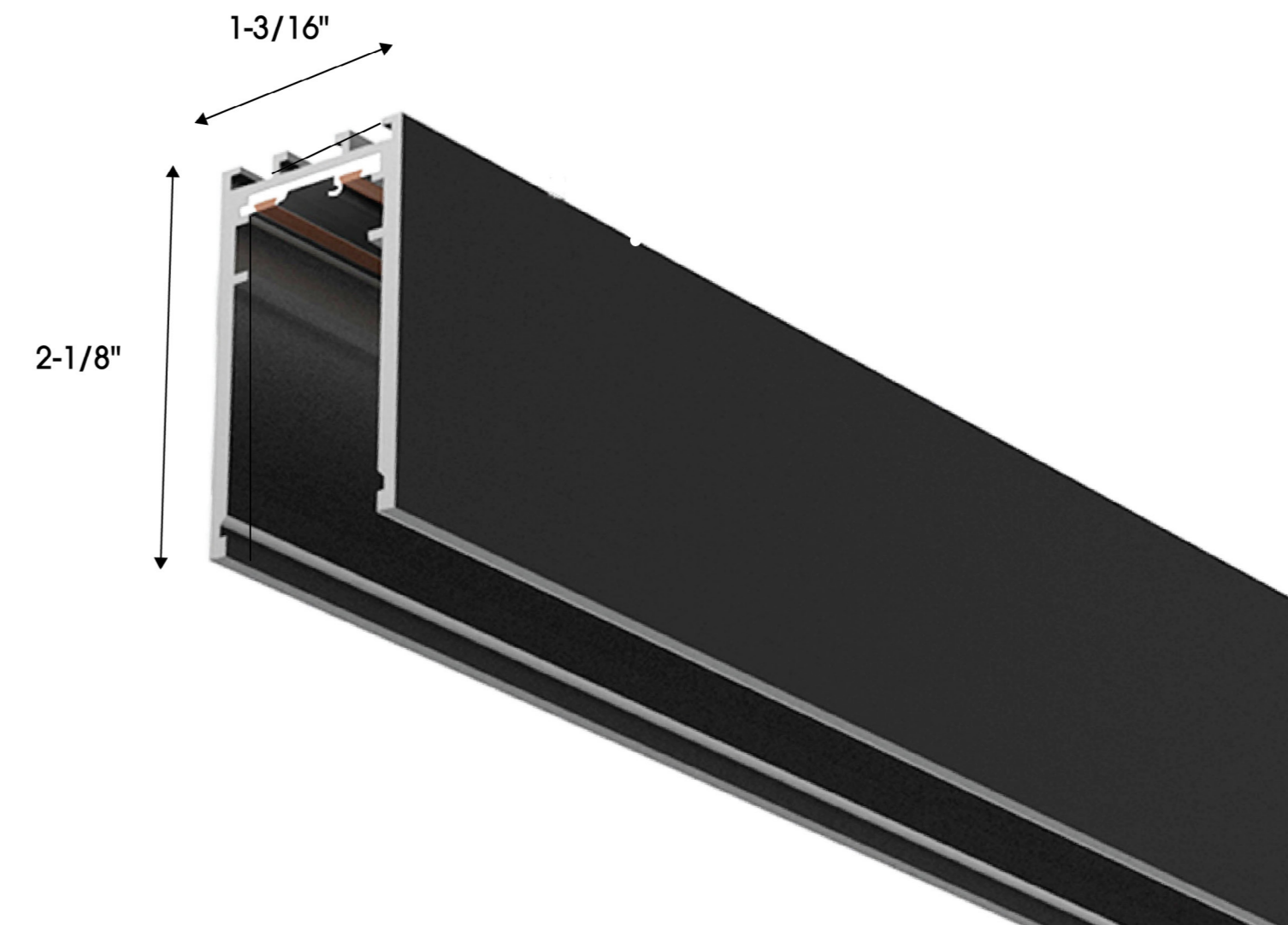

UNLIMITED EXPRESSION.

Metroline's **diverse modules** fit any project and space.

From precision directional cylinders that highlight artwork to refined tubular pendants, each one plugs right into the system to bring your vision together.

The system is available immediately in White and Black. For additional finishes, reach out to us for a quick consultation!

AVAILABLE IMMEDIATELY:

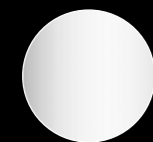

White

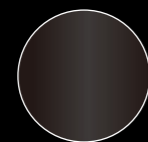

Black

INQUIRE FOR AVAILABILITY:

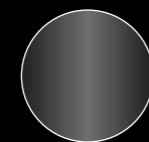

Anodized
Black

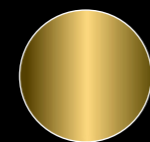

Anodized
Brass

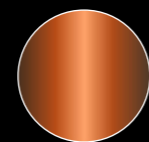

Anodized
Copper

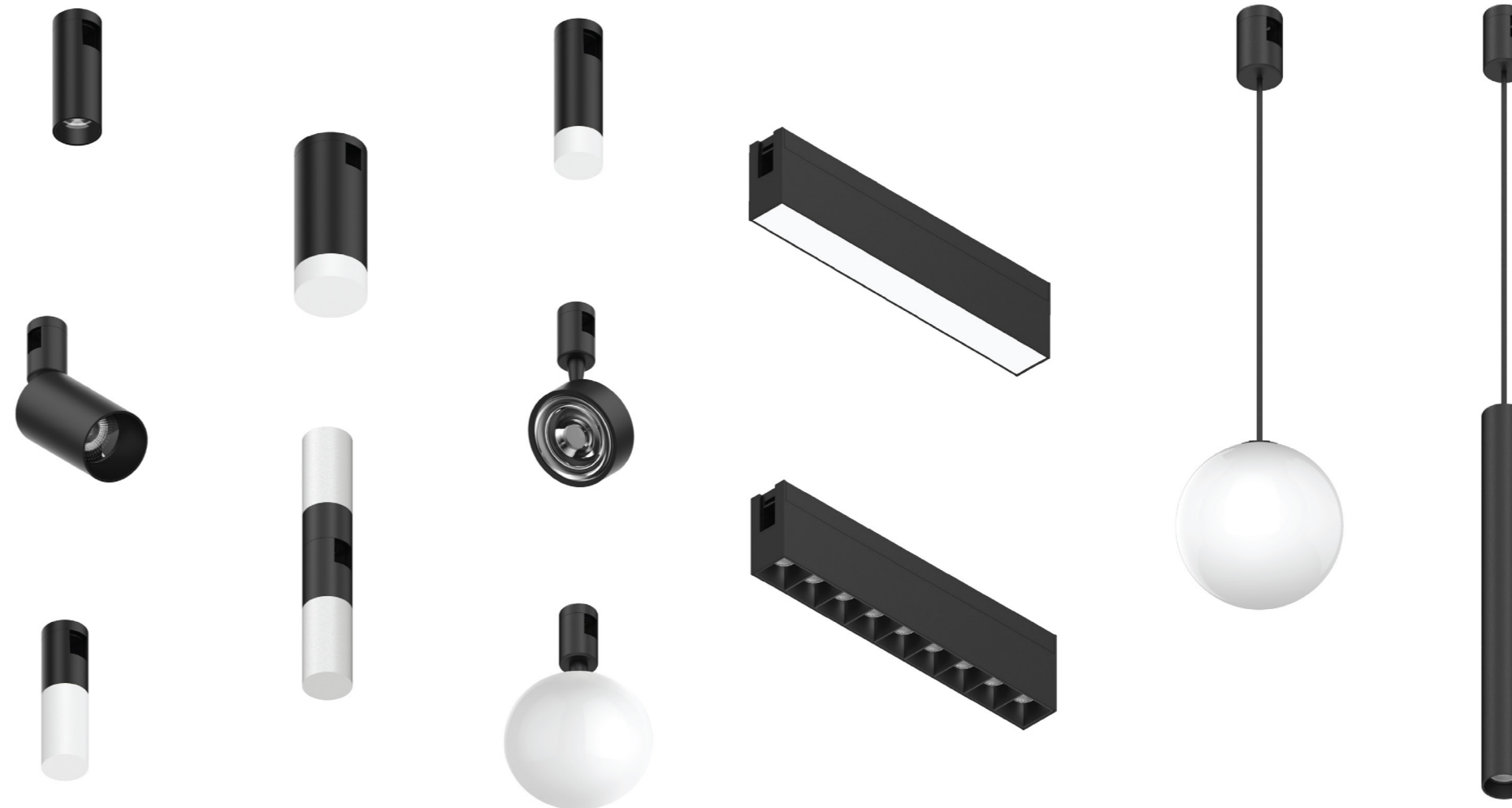

TOP-TIER PERFORMANCE

Experience true colors

With a Color Rendering Index (CRI) of 90+, Metroline delivers **rich and accurate color**, crucial for galleries, museums, retail, and any space where true color matters.

Precision you can see

Metroline uses TIR (Total Internal Reflection) optics for precise, glare-free lighting, delivering clean illumination exactly where needed.



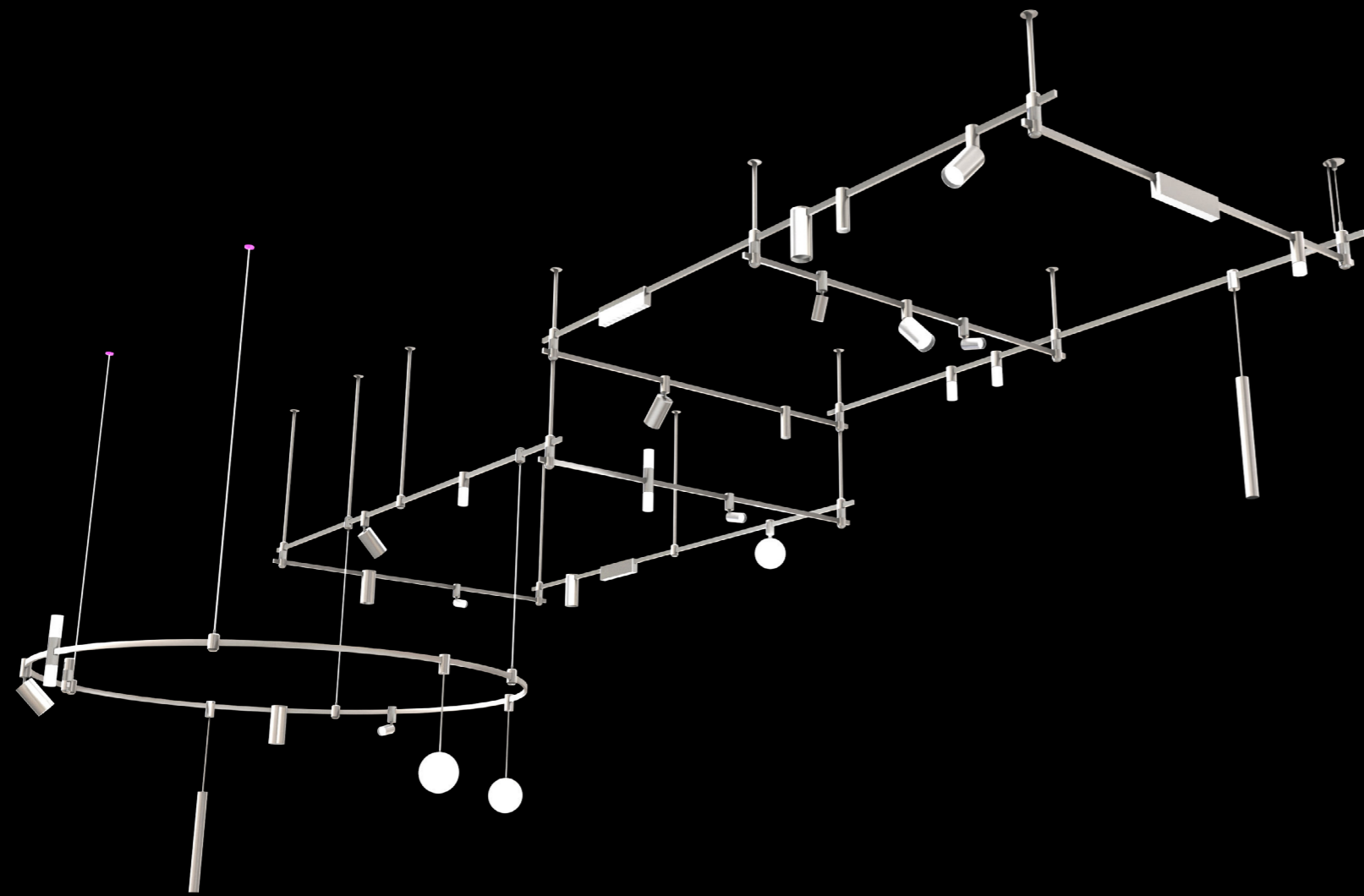

LAYERS OF LIGHT.

Metroline is a true multi-level lighting system. **Suspend rails at any height, layer them, stack them,** or combine them to create depth, hierarchy, and spatial definition that standard track systems can't match.

Designers no longer have to work within a single horizontal line. Metroline **makes lighting architectural:** structured, dimensional, and adapted to the space.

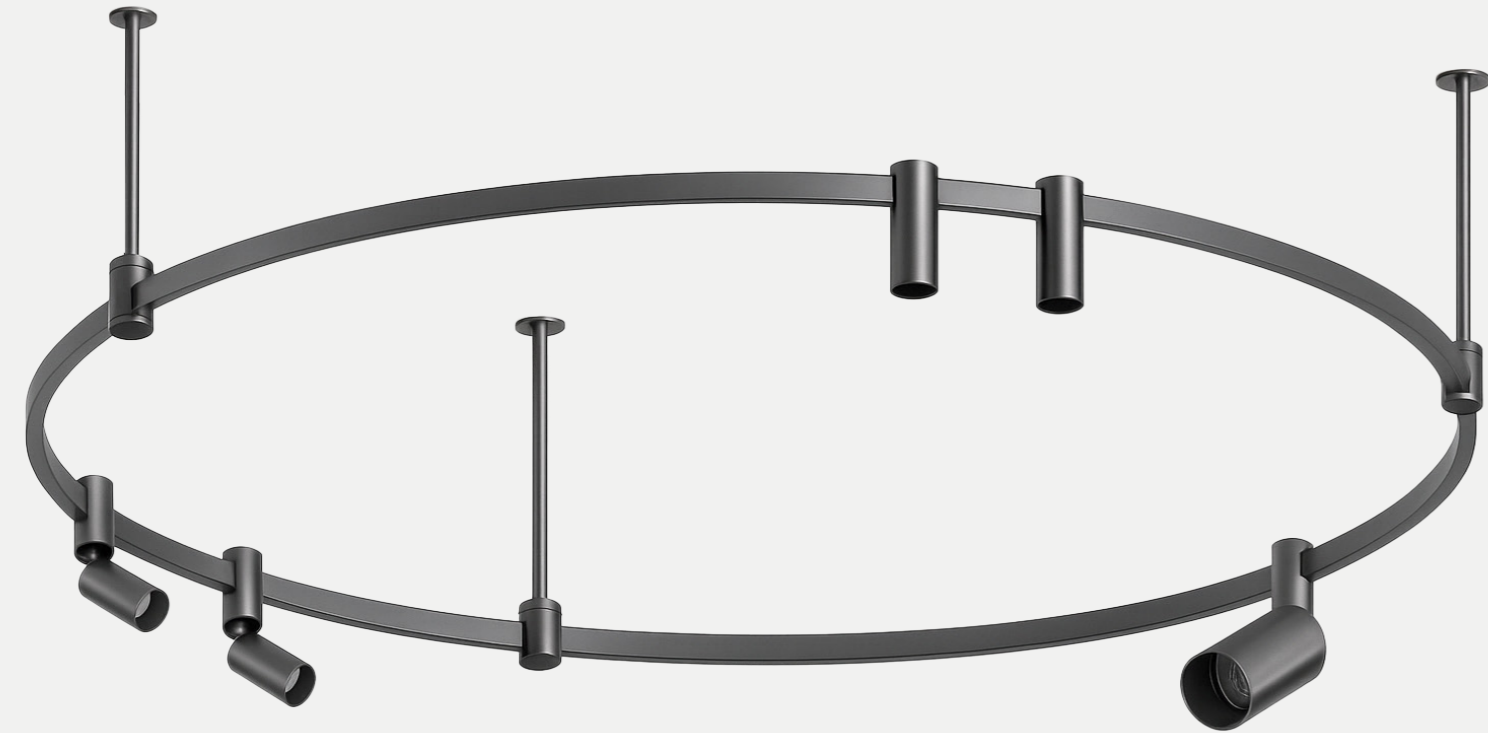

METROLINE RING

Metroline's flexibility **doesn't stop at straight runs**. The system also includes a circular rail option available in four diameters: 3'11", 4'11", 5'11", and 9'10".

Suspend them at any height and pair with all Metroline modules.

This lets you build **continuous, layered lighting** without compromising compatibility, performance, or design freedom.

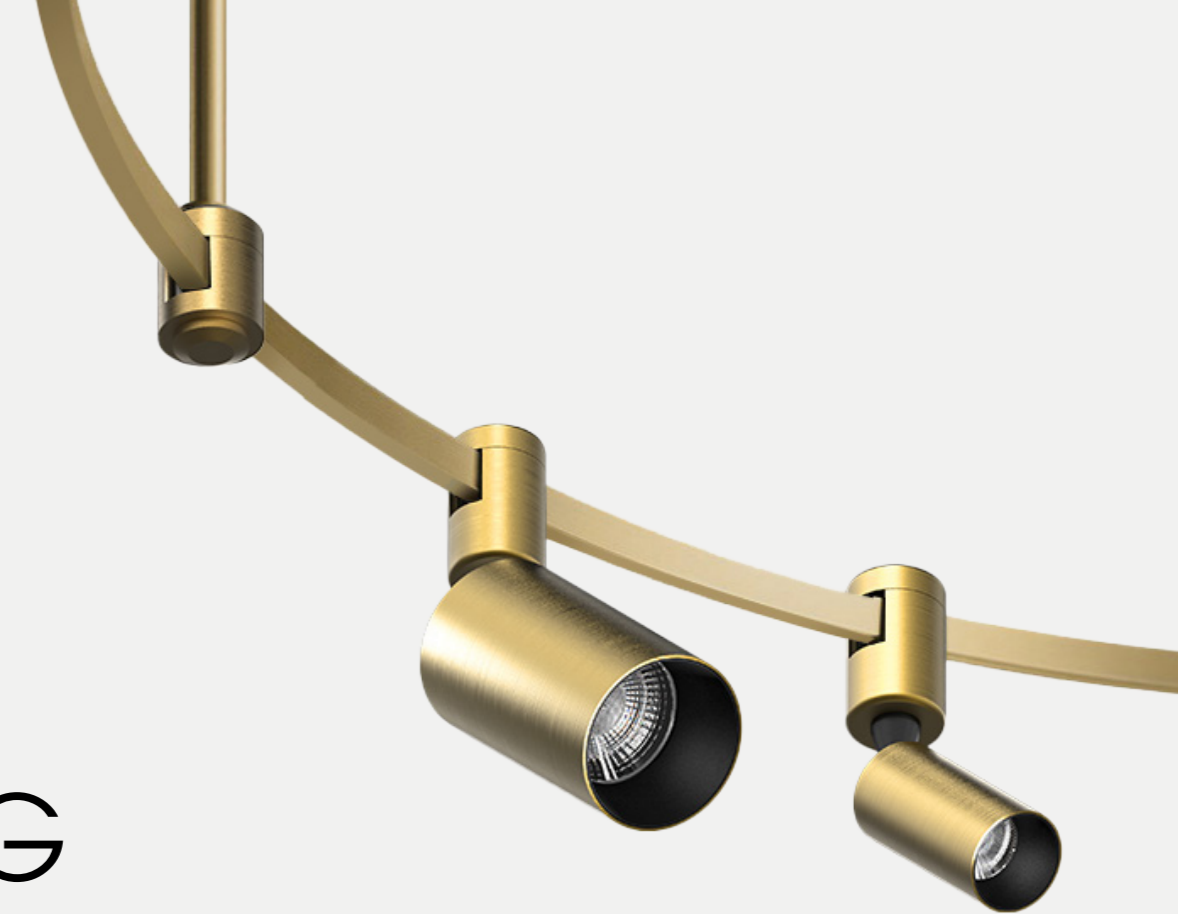



BEAUTY IN SIMPLICITY.

Metroline's clean, minimal aesthetic blends into any space. You don't have to choose between design and performance - with Metroline, you get both. From luxury retail and hospitality to offices and homes, Metroline feels right at home.

MANY APPLICATIONS, ONE SYSTEM.

Metroline is as flexible as it gets in lighting. No more worries with late design changes - this system can handle it all.

Suspended at any height and built across multiple levels, Metroline works with an extensive module family. The result is flexibility in bringing your design to life.

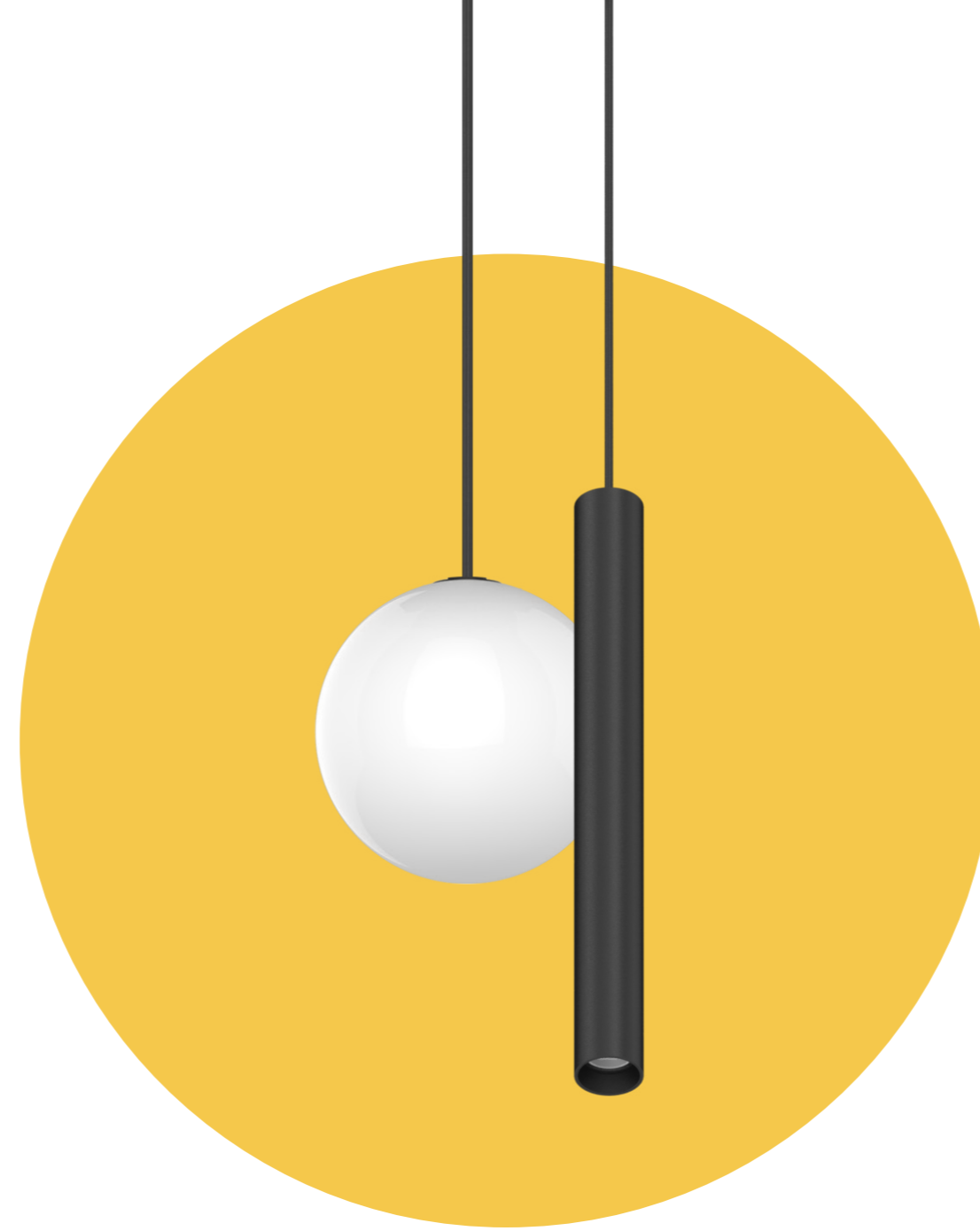

A VARIETY OF MODULES

Wide array of modules make this system perfect for any space. From directional cylinders to sleek pendants, Metroline has it all.

SPECIFIABLE LENGTHS AND ANGLES

This system adapts to any layout. You have the freedom to build the lighting that fits the space - not the other way around.

TRUSTED BY OUR PARTNERS.

Specifiers trust us to deliver exactly what we promise, and to be a partner they can count on.

Here are a few of the projects we've been a part of.

SWANN GALLERIES NYC
STUDIO MUSEUM OF HARLEM
CANTOR FITZGERALD
RALPH LAUREN
EXTRA BUTTER
WATERSHED FOUNDATION
UBER
ROTHY'S SHOES
LOEWS
MORGAN STANLEY
TISHMAN SPEYER
FOX NEWS STUDIOS
CRESTRON SHOWROOM
ATSRA ZENECA HEADQUARTERS
GOOGLE
IBM
BARCLAYS BANK
GOLDMAN SACHS

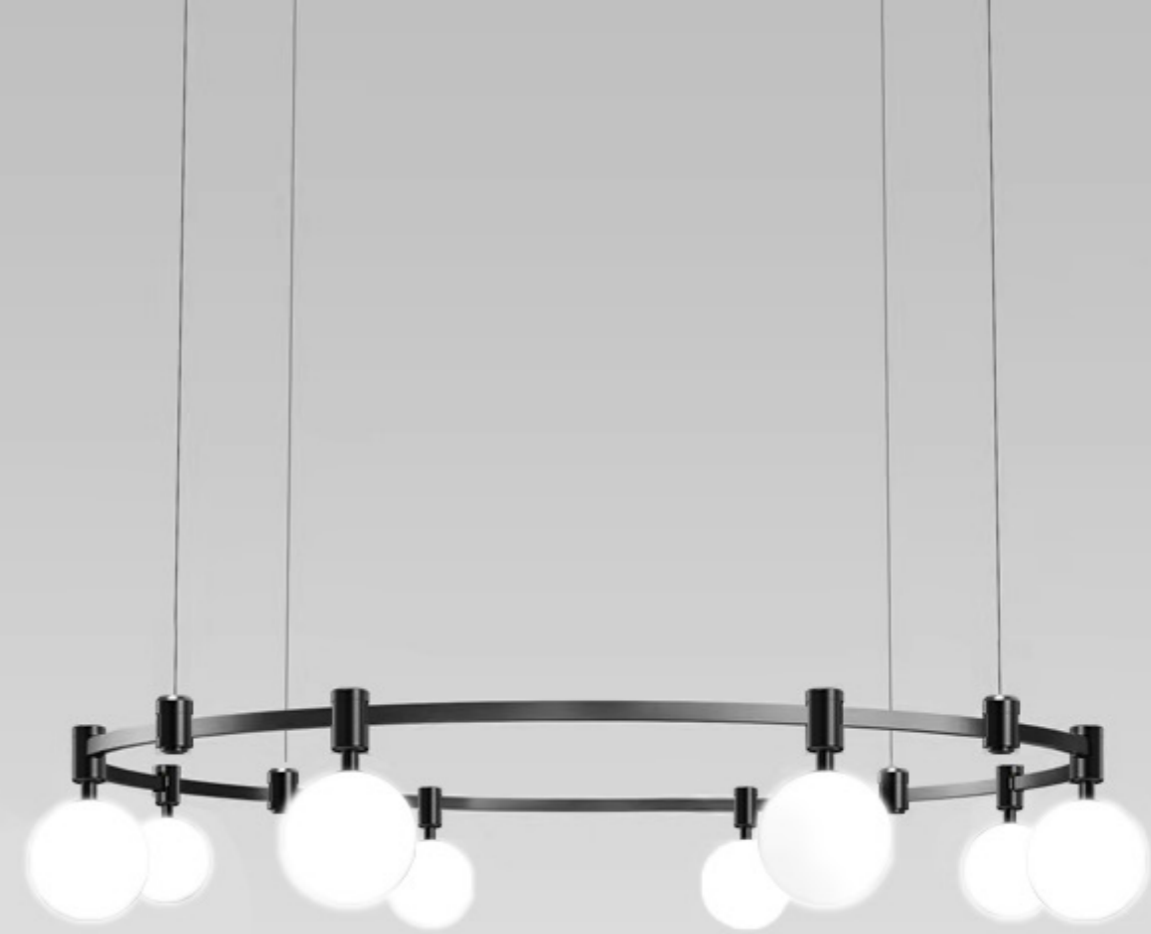



REACH OUT.

We're here to help with your project and find the right lighting for it!

Email: info@cosinelitg.com

Phone: (718) 887-6403